

## MARINA COMMITTEE MEETING

**DATE OF MEETING:** May 2, 2022 at 5:00 p.m. DeWitt County Building

**MEMBERS PRESENT:** Dan Matthews – Chair, Terry Ferguson, Travis Houser, Aaron Kammeyer and Jay Wickenhauser. Also, present, Dee Dee Rentmeister, County Administrator, Joe and Marybeth Caldwell- marina operators.

**MEMBERS ABSENT:** None

### SUMMARY OF DISCUSSION:

- Eric Bussell with Clinton Lake Sailing Association was present to discuss with the committee about starting the process to dispose of abandoned boats on their leased property. Committee informed Mr. Bussell that they had no issues with proceeding/starting the process of being able to dispose of abandoned boats.
- Received one bid for the removal of the islands in the parking lots from Ezell Excavating. Option 1 and Option 2 of the bid was to remove 6 islands in each lot separately - \$18,900 each. Option 3 which was to remove all 12 islands - \$34,900. Committee discussed how much of the work could be done by mid-May. Would like to have one lot completed prior to starting on the second lot. Motion by Kammeyer, 2<sup>nd</sup> by Houser to recommend to the full board to accept the bid from Ezell Excavating to remove all 12 islands in the parking lots at the marina for \$34,900. Voice vote, motion carried.
- Motion by Kammeyer, 2<sup>nd</sup> by House to approve last month's minutes. Voice vote, motion carried.
- Motion by Ferguson, 2<sup>nd</sup> by Kammeyer to approve the claims. Voice vote, motion carried.
- Discussion on parking on the lower-level parking area. Committee feels a letter should be sent out to slip renters informing them that the lower-level parking area is for vehicles only.
- Discussion on installing the breakwater. Will need to put together a bid packet for this project. Motion by Ferguson, 2<sup>nd</sup> by Kammeyer to put together a bid packet and send out for bids for the installation of the breakwater. Voice vote, motion carried.
- Review and discussion on the concrete anchors needed for the breakwater. Sixteen anchors are needed. Motion by Kammeyer, 2<sup>nd</sup> by Wickenhauser to approve \$5000 for concrete anchors. Voice vote, motion carried.
- Committee reviewed the draft bid packet for the gas dock breakwater. Will ask for an option for just the breakwater and another option for the breakwater with boat slips and ramp. Motion by Houser, 2<sup>nd</sup> by Kammeyer to accept the gas dock breakwater bid packet prepared by Chastain. Voice vote, motion carried.
- No action on the rip rap project. Will get more information.
- Matthews discussed with the committee about renewing the current lease with 1125 Property Management for another year. Motion by Matthews, 2<sup>nd</sup> by Kammeyer to recommend to the full board to renew the current lease agreement with 1125 Property Management for the 2023 year. Discussion ensued. Matthews indicated that a mechanic would be willing to come this year if they knew they would also be there another year, there is a lot of work that needs to be done this summer, the Board turnover on December 1<sup>st</sup> as some of the reasons that a contract extension is warranted. With all the projects needed, this committee does not have time to work on a new contract/bid package. Extension would allow the board more time to decide the future of the marina once the improvement is completed. Wickenhauser stated that a new contract is needed that gives the county more of the revenue, along with other language changes. How does the new dock 7 fall under the new contract? Need to have a letter from bank indicating that the \$40,000 letter of credit is still good with the current one-year extension along with proof of insurance in relation to liability and workman's compensation as outlined in the contract. After discussion voice vote was taken with Wickenhauser voting nay and Ferguson not voting. Other members voted aye. Motion carried.
- Discussed slip rental rate for dock 7 and what percentage goes to Joe and Marybeth. Committee feels that the new dock 7 slip rentals would be paid at the same percentage as all the other docks. Joe indicated that he would use his percentage of the rent from dock 7 to towards projects he feels need to

be addressed with the county agreeing. Discussed putting the jet skis on dock 7. Committee also indicated that those who had jet skis at the marina last and did not receive a refund would get a jet ski slip for free this year.

- Discussed new locks on the gates on all the docks. Joe will get information on replacing all the locks and bring back to the committee. Joe will also get quotes on solar lights for the walkway for dock 7.
- Discussed the need for a new electrical box and wiring for dock 5. Will put on the finance agenda.
- Joe informed the committee that the State should be out on Thursday to do a final inspection on the new gas dock.
- Wickenhauser asked about an incident at the marina this past Saturday where several people were allowed to stay in the apartments. Wickenhauser questioned whether this violated the lease contract. Joe indicated that the people were his cousins who stayed for the weekend and that they were not charged. Matthews indicated that he drove out to the marina on Saturday evening after he was notified that there were people at the marina and the building was open. He stated that the marina building was locked and secure when he got there. Slip renters called the sheriff's department to report. Kammeyer and Houser indicated that the marina was Joe and Marybeth's personal residence and that was ok that they allowed others to stay there. Wickenhauser stated that no one who isn't an employee, the lessee, contractors, etc. should be allowed to occupy the apartments or main buildings per the contract. Kammeyer, Houser and Matthews didn't think this was an issue. Matthews asked Joe and Marybeth to notify the committee in the future.
- Kammeyer asked about investing in some type of computer system for the marina that allowed online registration of slips and credit card payments.
- Motion by Houser, 2<sup>nd</sup> by Kammeyer to adjourn at 6:43 p.m. Voice vote, motion carried.

#### **COMMITTEE ACTION:**

Recommend to the full board to accept the bid from Ezell Excavating to remove all 12 islands in the parking lots at the marina for \$34,900.  
Approve last month's minutes.  
Approve the claims.  
Put together a bid packet and send out for bids for the installation of the breakwater.  
Approve \$5000 for concrete anchors.  
Accept the gas dock breakwater bid packet prepared by Chastain.  
Recommend to the full board to renew the current lease agreement with 1125 Property Management for the 2023 year.

#### **RECOMMENDATIONS TO THE BOARD:**

Recommend to the full board to accept the bid from Ezell Excavating to remove all 12 islands in the parking lots at the marina for \$34,900.  
Recommend to the full board to renew the current lease agreement with 1125 Property Management for the 2023 year.

**DATE OF NEXT MEETING: June 6, 2022 at 5:00 p.m. County Building**

**AGENDA FOR THE  
PROPERTY COMMITTEE**

Date and Time of Meeting: May 5, 2022 at 7:00 a.m. Location: County Building

1. Call Meeting to Order
2. Persons Wishing to Address the Committee/Public Comment (If requesting action, also list below in section three).
3. Items for Discussion and Possible Action
  - a. Approve last month's minutes
  - b. Approve the claims
  - c. Building inspections for jail and county buildings
  - d. Window film removal and reapplication of windows inside the jail area
  - e. Flooring replacement in the jail area – ARPA funds
4. Closed Session
5. Items for Discussion Only (No Action Requested)
  - a. Project updates
  - b.
6. Motion to adjourn.

Posted: May 2, 2022 at 8:40 p.m.

By: Dee Dee Rentmeister

Ezell Excavating Inc.  
 1574 County Road 100 N.  
 Villa Grove, IL. 61956 832-9066

# Bid Proposal

DATE	Bid Number
4/21/2022	455

<b>NAME / ADDRESS</b>
County of Dewitt 201 W. Washington St. Clinton, IL. 61727

DESCRIPTION	TOTAL
Bid Option #1 - \$18,900 Bid Option #2 - \$18,900 Bid Option #3 - \$34,900  <b>Option #1</b> Excavating service to remove 6 curbed islands in the NORTH parking lot at Clinton Marina. Each island is approximately 1350 sq. ft. Project to include:  Remove concrete curbing from site Remove sod and dirt to a depth of 6" below grade of parking lot. Stockpile material at the overflow parking area North of the paved lots. Backfill all island areas with a layer of 3" rock base, top remaining depth with compacted CA6 white rock. Material and labor = \$18,900.  <b>Option #2</b> Excavating service to remove 6 curbed islands in the CENTER parking lot at Clinton Marina. Each island is approximately 1350 sq. ft. Project to include:  Remove concrete curbing from site Remove sod and dirt to a depth of 6" below grade of parking lot. Stockpile material at the overflow parking area North of the paved lots. Backfill all island areas with a layer of 3" rock base, top remaining depth with compacted CA6 white rock. Material and labor = \$18,900.  <b>Alternative Bid</b> Excavating service to remove 12 curbed islands in the NORTH (6) and CENTER (6) parking lots at Clinton Marina. Each island is approximately 1350 sq. ft. Project to include:  Remove concrete curbing from site Remove sod and dirt to a depth of 6" below grade of parking lots. Stockpile material at the overflow parking area North of the paved lots. Backfill all island areas with a layer of 3" rock base, top remaining depth with compacted CA6 white rock. Material and labor = \$34,900.	18,900.00

**TOTAL**

SIGNATURE

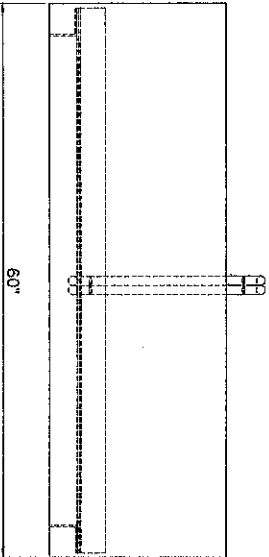
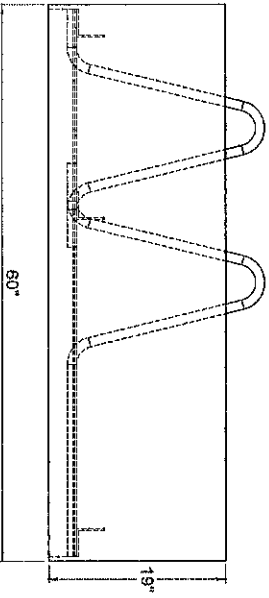
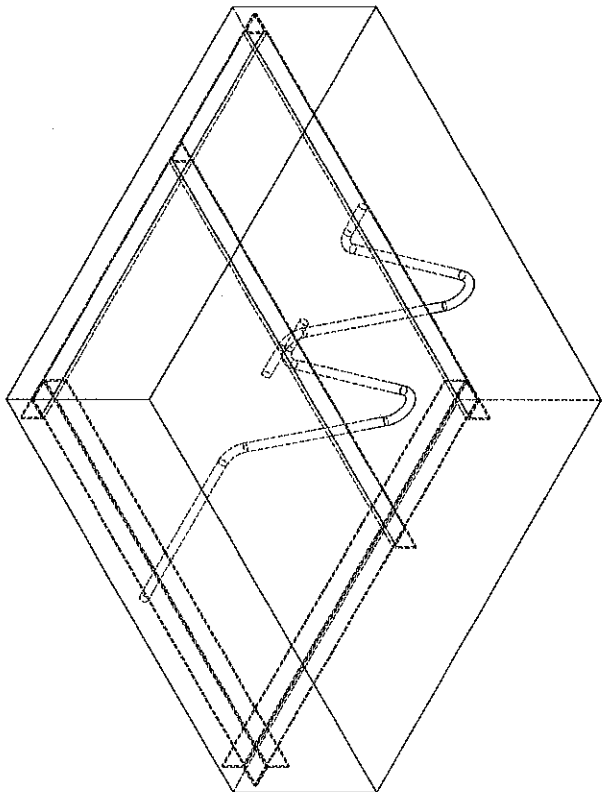
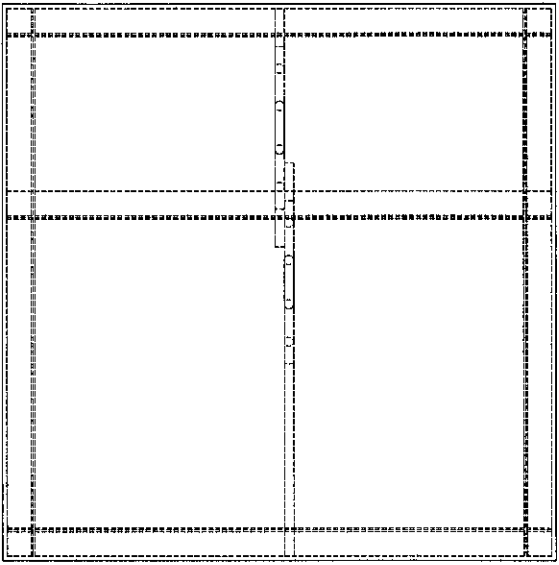

- NOTES:
1. WELDING: STEEL - CSA W47.1 ALUMINUM - CSA W47.2
  2. SQUARE WELD SIZE SHALL BE EQUAL TO THE THICKNESS OF MEMBERS BEING JOINED.
  3. ALL ALUMINUM STRUCTURAL MEMBERS ARE 4063-T6
  4. ALL STEEL STRUCTURAL MEMBERS ARE A44W
  5. UNLESS OTHERWISE SPECIFIED BOM IS STEEL

NOTES

**A** TITLE  
**B/C** SCALE

A DETAIL NUMBER  
 B SHEET NUMBER - WHERE DETAIL  
 C SECTION NUMBER - WHERE DETAIL  
 LOCATED

PART NUMBER

MODEL

3 Ton Anchor 2012

CUSTOMER

DRAWINGS

3 Ton Anchor 2012

DRAWN BY:

DRAWN DATE

SCALE

CHECKED BY:

REVISION DATE:

REV DESCRIPTION:

JOB NUMBER

SHEET NUMBER  
 OF

5 5



THIS DRAWING IS THE PROPERTY OF KROPE INDUSTRIAL AND IS NOT TO BE COPIED OR REPRODUCED WITHOUT WRITTEN PERMISSION

ITEM NO.	QTY.	FILE NAME	Part Number	DESCRIPTION	Width	Thickness	Height	Material	Length
1	1	Et		3 Ton Anchor Hook Main 2012	3"	1"	55 3/16"	RD	59"
2	5	59 Angle			3"	3/16"	3"	44W	59"
3	1	Center		3 Ton Anchor Hook Main 2012	1"	1"		RD	71 7/8"

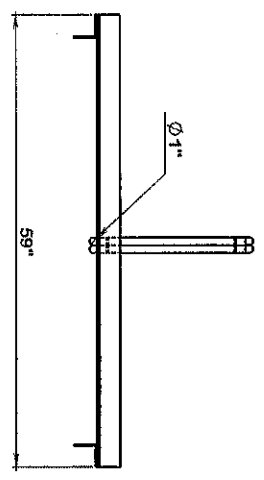
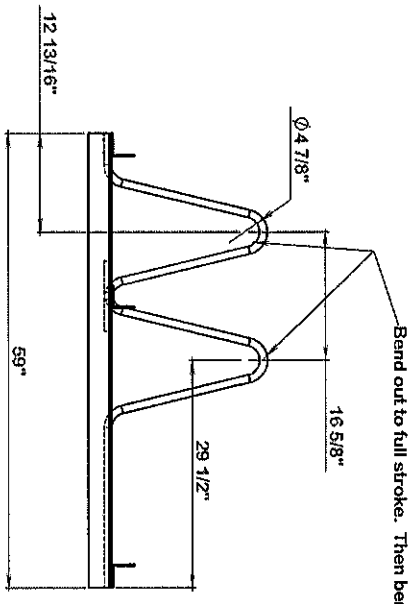
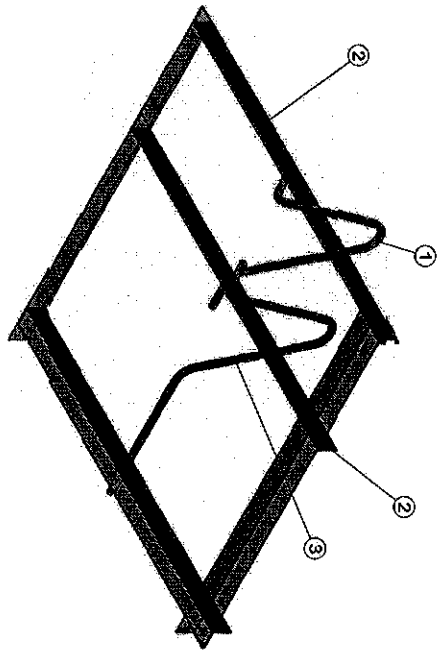
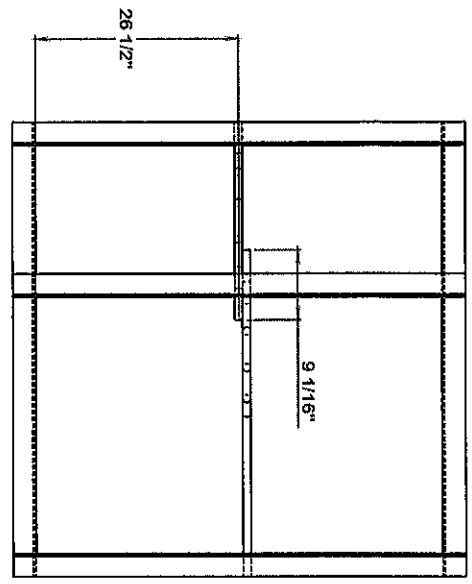

NOTES:  
 1. WELDING:  
 STEEL - CSA W44 7  
 ALUMINUM - CSA W44 7  
 2. ALL DIMENSIONS SHOWN WELD SIZE SHALL BE EQUIVALENT TO THICKNESS OF MEMBERS BEING JOINED.  
 3. ALL ALUMINUM STRUCTURAL MEMBERS ARE 44W.  
 4. UNLESS OTHERWISE SPECIFIED BOM IS STEEL.  
 5. SPECIFIED LOADS.

NOTES

**A** TITLE  
**B/C** SCALE

A. DETAIL NUMBER  
 B. SHEET NUMBER - WHERE DETAIL  
 C. SHEET NUMBER - WHERE DETAIL  
 LOCATED

PART NUMBER  
**DOCK007**

MODEL  
**Anchor Hook 3 Ton**

CUSTOMER

DRAWINGS  
**Anchor Hook 3 Ton 2012**

DRAWN BY:  
**MS**

CHECKED BY:

REV DESCRIPTION:

DRAWN DATE  
**Feb 20 12**

REVISION DATE:

SCALE



THIS DRAWING IS THE PROPERTY OF KROPP CONSULTING AND IS NOT TO BE COPIED OR REPRODUCED WITHOUT WRITTEN PERMISSION

JOB NUMBER

SHEET NUMBER  
 1 of 3